

FHF325 series

Maximum pressure up to 350 bar - Flow rate up to 500 l/min

Filter housing according to SAE J2066 for HF4 filter elements



FILTER SIZING

INDEX

	Page
CALCULATION	23
CORRECTIVE FACTOR	24

THE CORRECT FILTER SIZING HAVE TO BE BASED ON THE TOTAL PRESSURE DROP DEPENDING BY THE APPLICATION.

FOR EXAMPLE, THE MAXIMUM TOTAL PRESSURE DROP ALLOWED BY A NEW AND CLEAN RETURN FILTER HAVE TO BE IN THE RANGE 0.4 ÷ 0.6 bar.

The pressure drop calculation is performed by adding together the value of the housing with the value of the filter element. The pressure drop Δpc of the housing is proportional to the fluid density (kg/dm³); all the graphs in the catalogue are referred to mineral oil with density of 0.86 kg/dm³.

The filter element pressure drop Δpe is proportional to its viscosity (mm²/s), the corrective factor Y have to be used in case of an oil viscosity different than 30 mm²/s (cSt).

Sizing data for single filter element, head at top

Δpc = Filter housing pressure drop [bar]

Δpe = Filter element pressure drop [bar]

Y = Corrective factor Y (see correspondent table), depending on the filter type, on the filter element size, on the filter element length and on the filter media

Q = flow rate (l/min)

V1 reference oil viscosity = 30 mm²/s (cSt)

V2 = operating oil viscosity in mm²/s (cSt)

Filter element pressure drop calculation with an oil viscosity different than 30 mm²/s (cSt)

$\Delta pe = Y : 1000 \times Q \times (V2:V1)$

$\Delta p Tot. = \Delta pc + \Delta pe$

Verification formula

$\Delta p Tot. \leq \Delta p max allowed$

Maximum total pressure drop (Δp max) allowed by a new and clean filter

Application	Range (bar)
Suction filters	0.08 ÷ 0.10
Return filters	0.4 ÷ 0.6
	0.4 ÷ 0.6 return lines
	0.3 ÷ 0.5 lubrication lines
Low & Medium Pressure filters	0.3 ÷ 0.4 off-line in power systems
	0.1 ÷ 0.3 off-line in test benches
	0.4 ÷ 0.6 over-boost
High Pressure filters	0.8 ÷ 1.5
Stainless Steel filters	0.8 ÷ 1.5

Generic filter calculation example

Application data:

Tank top return filter

Pressure Pmax = 10 bar

Flow rate Q = 120 l/min

Viscosity V2 = 46 mm²/s (cSt)

Oil density = 0.86 kg/dm³

Required filtration efficiency = 25 μm with absolute filtration

With bypass valve and G 1 1/4" inlet connection

Calculation:

Δpc = 0.03 bar (see graphic below)

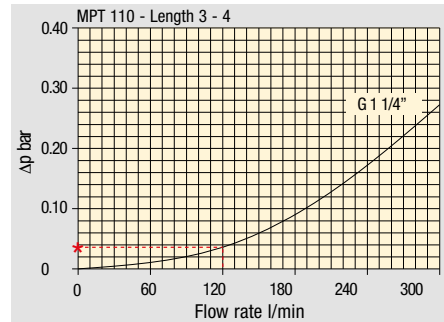

Filter housings Δp pressure drop. The curves are plotted using mineral oil with density of 0.86 kg/dm³ in compliance with ISO 3968. Δp varies proportionally with density.

$\Delta pe = (2.00 : 1000) \times 120 \times (46 : 30) = 0.37 bar$

Filter element	Absolute filtration H Series					Nominal filtration N Series		
	A03	A06	A10	A16	A25	P10	P25	M25 M60 M90
Type								
Return filters								
MF 020	74.00	50.08	20.00	16.00	9.00	6.43	5.51	4.40
	2	29.20	24.12	8.00	7.22	5.00	3.33	2.85
	3	22.00	19.00	6.56	5.33	4.33	1.68	1.44
MF 030	74.00	50.08	20.00	16.00	9.00	6.43	5.51	3.40
MFX 030	1	28.20	24.40	8.67	8.17	6.88	4.62	3.96
	2	17.33	12.50	6.86	5.70	4.00	3.05	2.47
	3	10.25	9.00	3.65	3.33	2.50	1.63	1.32
	4	6.10	5.40	2.30	2.20	2.00	1.19	0.96

$\Delta p Tot. = 0.03 + 0.37 = 0.4 bar$

The selection is correct because the total pressure drop value is inside the admissible range for top tank return filters.

In case the allowed max total pressure drop is not verified, it is necessary to repeat the calculation changing the filter length/size.

FILTER SIZING Corrective factor

Corrective factor Y to be used for the filter element pressure drop calculation. The values depend to the filter size and length and to the filter media.
Reference oil viscosity 30 mm²/s

Return filters

Filter element	Absolute filtration H Series					Nominal filtration N Series			
	Type	A03	A06	A10	A16	A25	P10	P25	M25 M60 M90
MF 020	1	74.00	50.08	20.00	16.00	9.00	6.43	5.51	4.40
	2	29.20	24.12	8.00	7.22	5.00	3.33	2.85	2.00
	3	22.00	19.00	6.56	5.33	4.33	1.68	1.44	1.30
MF 030 MFX 030	1	74.00	50.08	20.00	16.00	9.00	6.43	5.51	3.40
MF 100 MFX 100	1	28.20	24.40	8.67	8.17	6.88	4.62	3.96	1.25
	2	17.33	12.50	6.86	5.70	4.00	3.05	2.47	1.10
	3	10.25	9.00	3.65	3.33	2.50	1.63	1.32	0.96
	4	6.10	5.40	2.30	2.20	2.00	1.19	0.96	0.82
MF 180 MFX 180	1	3.67	3.05	1.64	1.56	1.24	1.18	1.06	0.26
	2	1.69	1.37	0.68	0.54	0.51	0.43	0.39	0.12
MF 190 MFX 190	2	1.69	1.37	0.60	0.49	0.44	0.35	0.31	0.11
MF 400 MFX 400	1	3.20	2.75	1.39	1.33	1.06	0.96	0.87	0.22
	2	2.00	1.87	0.88	0.85	0.55	0.49	0.45	0.13
	3	1.90	1.60	0.63	0.51	0.49	0.39	0.35	0.11
MF 750 MFX 750	1	1.08	0.84	0.49	0.36	0.26	0.21	0.19	0.06
MLX 250	2	3.00	3.04	1.46	1.25	1.17	-	-	M25 0.20
MLX 660	2	1.29	1.26	0.52	0.44	0.38	-	-	M25 0.10
CU 025		78.00	48.00	28.00	24.00	9.33	9.33	8.51	1.25
CU 040		25.88	20.88	10.44	10.00	3.78	3.78	3.30	1.25
CU 100		15.20	14.53	5.14	4.95	2.00	2.00	0.17	1.10
CU 250		3.25	2.55	1.55	1.35	0.71	0.71	0.59	0.25
CU 630		1.96	1.68	0.85	0.72	0.42	0.42	0.36	0.09
CU 850		1.06	0.84	0.42	0.33	0.17	0.17	0.13	0.04
MR 100	1	19.00	17.00	6.90	6.30	4.60	2.94	2.52	1.60
	2	11.70	10.80	4.40	4.30	3.00	2.94	2.52	1.37
	3	7.80	6.87	3.70	3.10	2.70	2.14	1.84	1.34
	4	5.50	4.97	2.60	2.40	2.18	1.72	1.47	1.34
	5	4.20	3.84	2.36	2.15	1.90	1.60	1.37	1.34
MR 250	1	5.35	4.85	2.32	1.92	1.50	1.38	1.20	0.15
	2	4.00	3.28	1.44	1.10	1.07	0.96	0.83	0.13
	3	2.60	2.20	1.08	1.00	0.86	0.77	0.64	0.12
	4	1.84	1.56	0.68	0.56	0.44	0.37	0.23	0.11
MR 630	1	3.10	2.48	1.32	1.14	0.92	0.83	0.73	0.09
	2	2.06	1.92	0.82	0.76	0.38	0.33	0.27	0.08
	3	1.48	1.30	0.60	0.56	0.26	0.22	0.17	0.08
	4	1.30	1.20	0.48	0.40	0.25	0.21	0.16	0.08
	5	0.74	0.65	0.30	0.28	0.13	0.10	0.08	0.04
MR 850	1	0.60	0.43	0.34	0.25	0.13	0.12	0.09	0.03
	2	0.37	0.26	0.23	0.21	0.11	0.08	0.07	0.03
	3	0.27	0.18	0.17	0.17	0.05	0.04	0.04	0.02
	4	0.23	0.16	0.13	0.12	0.04	0.03	0.03	0.02

Return / Suction filters

Filter element	Absolute filtration								
	Type	A10	A16	A25					
RSX 116	1	5.12	4.33	3.85					
	2	2.22	1.87	1.22					
RSX 165	1	2.06	1.75	1.46					
	2	1.24	1.05	0.96					
	3	0.94	0.86	0.61					
Filter element	Absolute filtration N Series								
Type	A03	A06	A10	A16	A25	P10	P25	M25 M60 M90	
CU 110	1	16.25	15.16	8.75	8.14	5.87	2.86	2.65	0.14
	2	12.62	10.44	6.11	6.02	4.16	1.60	1.49	0.12
	3	8.57	7.95	5.07	4.07	2.40	1.24	1.15	0.11
	4	5.76	4.05	2.80	2.36	1.14	0.91	0.85	0.05

Low & Medium pressure filters

Filter element	Absolute filtration N-W Series					Nominal filtration N Series			
	Type	A03	A06	A10	A16	A25	P10	P25	M25
CU 110	1	16.25	15.16	8.75	8.14	5.87	2.86	2.65	0.14
	2	12.62	10.44	6.11	6.02	4.15	1.60	1.49	0.12
	3	8.57	7.95	5.07	4.07	2.40	1.24	1.15	0.11
	4	5.76	4.05	2.80	2.36	1.14	0.91	0.85	0.05
CU 210	1	5.30	4.80	2.00	1.66	1.32	0.56	0.43	0.12
	2	3.44	2.95	1.24	1.09	0.70	0.42	0.35	0.09
	3	2.40	1.70	0.94	0.84	0.54	0.33	0.23	0.05
DN	016	7.95	7.20	3.00	2.49	1.98	0.84	0.65	0.18
	025	5.00	4.53	1.89	1.57	1.25	0.53	0.41	0.11
	040	3.13	2.66	1.12	0.98	0.63	0.38	0.32	0.08
CU 400	2	3.13	2.55	1.46	1.22	0.78	0.75	0.64	0.19
	3	2.15	1.70	0.94	0.78	0.50	0.40	0.34	0.10
	4	1.60	1.28	0.71	0.61	0.40	0.34	0.27	0.08
	5	1.00	0.83	0.47	0.34	0.20	0.24	0.19	0.06
	6	0.82	0.58	0.30	0.27	0.17	0.22	0.18	0.05
	CU 900	1	0.86	0.63	0.32	0.30	0.21	-	-
CU 950	2	1.03	0.80	0.59	0.40	0.26	-	-	0.05
	3	0.44	0.40	0.27	0.18	0.15	-	-	0.02
MR 630	7	0.88	0.78	0.36	0.34	0.16	0.12	0.96	0.47

Corrective factor Y to be used for the filter element pressure drop calculation. The values depend to the filter size and length and to the filter media.
Reference oil viscosity 30 mm²/s

High pressure filters

Filter element		Absolute filtration N - R Series					Nominal filtration N Series
Type		A03	A06	A10	A16	A25	M25
HP 011	1	332.71	250.07	184.32	152.36	128.36	-
	2	220.28	165.56	74.08	59.13	37.05	-
	3	123.24	92.68	41.48	33.08	20.72	-
	4	77.76	58.52	28.37	22.67	16.17	-
HP 039	2	70.66	53.20	25.77	20.57	14.67	4.90
	3	36.57	32.28	18.00	13.38	8.00	2.90
	4	26.57	23.27	12.46	8.80	5.58	2.20
HP 050	1	31.75	30.30	13.16	12.3	7.29	1.60
	2	24.25	21.26	11.70	9.09	4.90	1.40
	3	17.37	16.25	8.90	7.18	3.63	1.25
	4	12.12	10.75	6.10	5.75	3.08	1.07
	5	7.00	6.56	3.60	3.10	2.25	0.80
HP 065	1	58.50	43.46	23.16	19.66	10.71	1.28
	2	42.60	25.64	16.22	13.88	7.32	1.11
	3	20.50	15.88	8.18	6.81	3.91	0.58
HP 135	1	20.33	18.80	9.71	8.66	4.78	2.78
	2	11.14	10.16	6.60	6.38	2.22	1.11
	3	6.48	6.33	3.38	3.16	2.14	1.01
HP 150	1	17.53	15.91	7.48	6.96	5.94	1.07
	2	8.60	8.37	3.54	3.38	3.15	0.58
	3	6.53	5.90	2.93	2.79	2.12	0.49
HP 320	1	10.88	9.73	5.02	3.73	2.54	1.04
	2	4.40	3.83	1.75	1.48	0.88	0.71
	3	2.75	2.11	1.05	0.87	0.77	0.61
	4	2.12	1.77	0.98	0.78	0.55	0.47
HP 500	1	4.44	3.67	2.30	2.10	1.65	0.15
	2	3.37	2.77	1.78	1.68	1.24	0.10
	3	2.22	1.98	1.11	1.09	0.75	0.08
	4	1.81	1.33	0.93	0.86	0.68	0.05
	5	1.33	1.15	0.77	0.68	0.48	0.04

Filter element		Absolute filtration N Series					Nominal filtration N Series
Type		A03	A06	A10	A16	A25	M25
HF 320	1	3.65	2.95	2.80	1.80	0.90	0.38
	2	2.03	1.73	1.61	1.35	0.85	0.36
	3	1.84	1.42	1.32	1.22	0.80	0.35

Suction filters

Filter element	Nominal filtration N Series	
Type	P10	P25
SF 250	65	21

Stainless steel high pressure filters

Filter element		Absolute filtration N Series				
Type		A03	A06	A10	A16	A25
HP 011	1	332.71	250.07	184.32	152.36	128.36
	2	220.28	165.56	74.08	59.13	37.05
	3	123.24	92.68	41.48	33.08	20.72
	4	77.76	58.52	28.37	22.67	16.17
HP 039	2	70.66	53.20	25.77	20.57	14.67
	3	36.57	32.28	18.00	13.38	8.00
	4	26.57	23.27	12.46	8.80	5.58
HP 050	1	31.75	30.30	13.16	12.3	7.29
	2	24.25	21.26	11.70	9.09	4.90
	3	17.37	16.25	8.90	7.18	3.63
	4	12.12	10.75	6.10	5.75	3.08
	5	7.00	6.56	3.60	3.10	2.25
HP 135	1	20.33	18.80	9.71	8.66	4.78
	2	11.14	10.16	6.60	6.38	2.22
	3	6.48	6.33	3.38	3.16	2.14

Filter element		Absolute filtration H - U Series				
Type		A03	A06	A10	A16	A25
HP 011	1	424.58	319.74	235.17	194.44	163.78
	2	281.06	211.25	94.53	75.45	47.26
	3	130.14	97.50	43.63	34.82	21.81
	4	109.39	82.25	36.79	29.37	18.40
HP 039	2	70.66	53.20	25.77	20.57	14.67
	3	36.57	32.28	18.00	13.38	8.00
	4	26.57	23.27	12.46	8.80	5.58
HP 050	1	47.33	34.25	21.50	20.50	14.71
	2	29.10	25.95	14.04	10.90	5.88
	3	20.85	19.50	10.68	8.61	4.36
	4	14.55	12.90	7.32	6.90	3.69
	5	9.86	9.34	6.40	4.80	2.50
HP 135	1	29.16	25.33	13.00	12.47	5.92
	2	14.28	11.04	7.86	7.60	4.44
	3	8.96	7.46	4.89	4.16	3.07

FILTER SIZING Selection Software

Step 1 Select "FILTERS"



Step 2 Choose filter group (Return Filter, Pressure Filter, etc.)



Step 3 Choose filter type (MPF, MPT, etc.) in function of the max working pressure and the max flow rate



Step 4 Push "PROCEED"

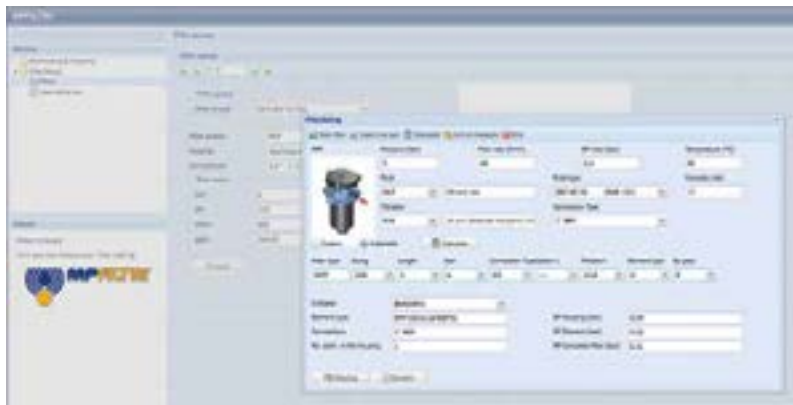

Step 5

Insert all application data to calculate the filter size following the sequence:

- working pressure
- working flow rate
- working pressure drop
- working temperature
- fluid material and fluid type
- filtration media
- connection type

Step 6

Push "CALCULATE" to have result; in case of any mistake, the system will advice which parameter is out of range to allow to modify/adjust the selection

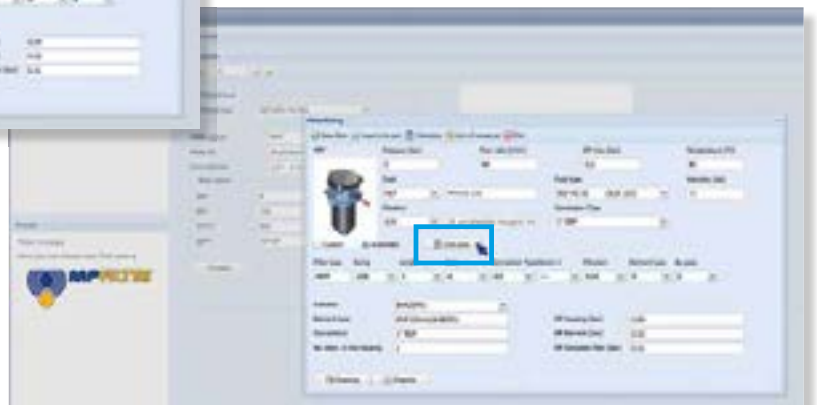

Step 7

Download PDF Datasheet "Report.aspx" pushing the button "Drawing"

FHF325 series

Maximum pressure up to 350 bar - Flow rate up to 500 l/min

Filter housing according to SAE J2066 for HF4 filter elements



FHF325 GENERAL INFORMATION

Filter housing according to SAE J2066 for HF4 filter elements

Description

High Pressure filters

Manifold

Maximum pressure up to 350 bar

Flow rate up to 500 l/min

FHF is a range of high pressure filter for protection of sensitive components in high pressure hydraulic systems in the mobile machines. They are directly connected to the lines of the system through the hydraulic fittings or the proper flanged interface.

Available features:

- 1 1/2" female threaded connections, 1 1/2" flanged connections and manifold connections up to 1 1/2", for a maximum flow rate of 500 l/min
- Base-mounting design, for ease of the replacement of the filter element
- Filter element designed in accordance with SAE J2066 HF4 regulation
- Fine filtration rating, to get a good cleanliness level into the system
- Bypass valve, to relieve excessive pressure drop across the filter media
- Low collapse filter element "N", for use with filters provided with bypass valve
- Visual, electrical and electronic differential clogging indicators

Common applications:

Delivery lines, in any high pressure industrial equipment

Technical data

Filter housing materials

- Head: Phosphatized cast iron
- Housing: Phosphatized steel
- Cover: Cast iron (chemical heat treatment)
- Bypass valve: Brass - Steel

Pressure

- Working pressure: 35 MPa (350 bar)
- Test pressure: 52.5 MPa (525 bar)
- Burst pressure: 105 MPa (1050 bar)
- Pulse pressure fatigue test: 1 000 000 cycles with pressure from 0 to 35 MPa (350 bar)

Bypass valve

- Opening pressure 600 kPa (6 bar) $\pm 10\%$
- Other opening pressures on request.

Δp element type

- Microfibre filter elements - series N: 20 bar
- Wire mesh filter elements - series N: 20 bar
- Fluid flow through the filter element from OUT to IN.

Seals

- Standard NBR series A
- Optional FPM series V

Temperature

From -25 °C to +110 °C

Connections

- FHF 325: In-line threaded connection
- FHF 325: In-line flanged connection
- FHF 325: Manifold mounting

Note

FHF filters are provided for vertical mounting



Weights [kg] and volumes [dm³]

Filter series	Weights [kg]			Volumes [dm ³]				
	Length	1	2	3	Length	1	2	3
FHF 325		23.90	32.68	41.47		3.50	5.80	8.11

Pressure drop

Filter housings Δp pressure drop

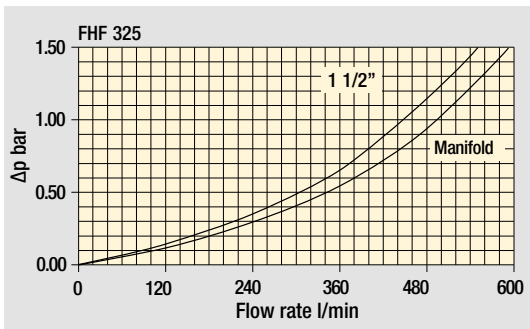

The curves are plotted using mineral oil with density of 0.86 kg/dm^3 in compliance with ISO 3968. Δp varies proportionally with density.

Flow rates [l/min]

Filter series	Length	Filter element design - N Series					
		A03	A06	A10	A16	A25	M25
FHF 325	1	302	339	348	419	500	556
	2	401	424	434	457	505	557
	3	416	451	460	469	510	559

Maximum flow rate for a complete pressure filter with a pressure drop $\Delta p = 1.5 \text{ bar}$.

The reference fluid has a kinematic viscosity of $30 \text{ mm}^2/\text{s}$ (cSt) and a density of 0.86 kg/dm^3 .

For different pressure drop or fluid viscosity we recommend to use our selection software available on www.mpfiltri.com.

Please, contact our Sales Department for further additional information.

Hydraulic symbols

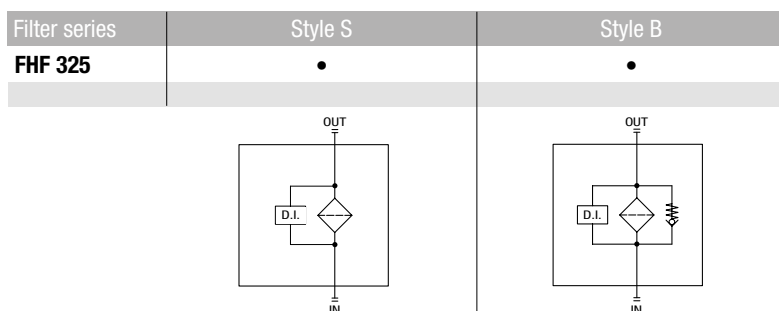

FHF325

Designation & Ordering code

COMPLETE FILTER

Series and size	Configuration example: FHF325 2 S A H 7 A10 N P01									
FHF325										
Length										
1 2 3										
Valves										
S Without bypass										
B With bypass 6 bar										
Seals										
A NBR										
V FPM										
Connections										
A G 1 1/2"										
B 1 1/2" NPT										
C SAE 24 - 1 7/8" - 12 UN										
G 1 1/2" SAE 6000 psi/M										
H 1 1/2" SAE 6000 psi/UNC										
M Manifold ø1.38"										
N Manifold ø1.50"										
Connection for differential indicator										
7 With two connections plugged on both sides										
Filtration rating (filter media)										
A03 Inorganic microfiber 3 µm	A16 Inorganic microfiber 16 µm									
A06 Inorganic microfiber 6 µm	A25 Inorganic microfiber 25 µm									
A10 Inorganic microfiber 10 µm	M25 Wire mesh 25 µm									
		Element Δp		Execution						
		N 20 bar		P01 MP Filtri standard						
				Pxx Customized						

FILTER ELEMENT

Element series and size	Configuration example: HF325 2 A10 A N P01						
HF325							
Element length							
1 2 3							
Filtration rating (filter media)							
A03 Inorganic microfiber 3 µm	A16 Inorganic microfiber 16 µm						
A06 Inorganic microfiber 6 µm	A25 Inorganic microfiber 25 µm						
A10 Inorganic microfiber 10 µm	M25 Wire mesh 25 µm						
		Seals		Element Δp		Execution	
		A NBR		N 20 bar		P01 MP Filtri standard	
		V FPM				Pxx Customized	

ACCESSORIES

Differential indicators		page			page
DEA	Electrical differential indicator	563	DLE	Electrical / visual differential indicator	566
DEH	Hazardous area electronic differential indicator	563-564	DTA	Electronic differential indicator	567
DEM	Electrical differential indicator	564-565	DVA	Visual differential indicator	567
DLA	Electrical / visual differential indicator	565-566	DVM	Visual differential indicator	567
Additional features		page			
T2	Plug	568			

FHF325		
Connection A - B - C		
Filter length	H [mm]	H2 [mm]
1	452	250
2	690	485
3	928	725

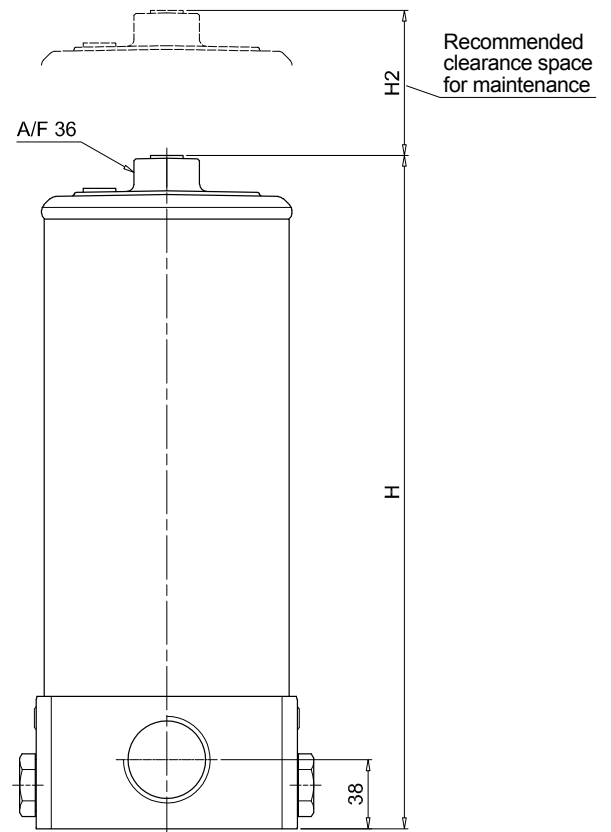
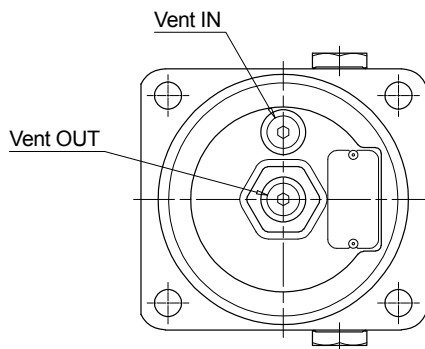
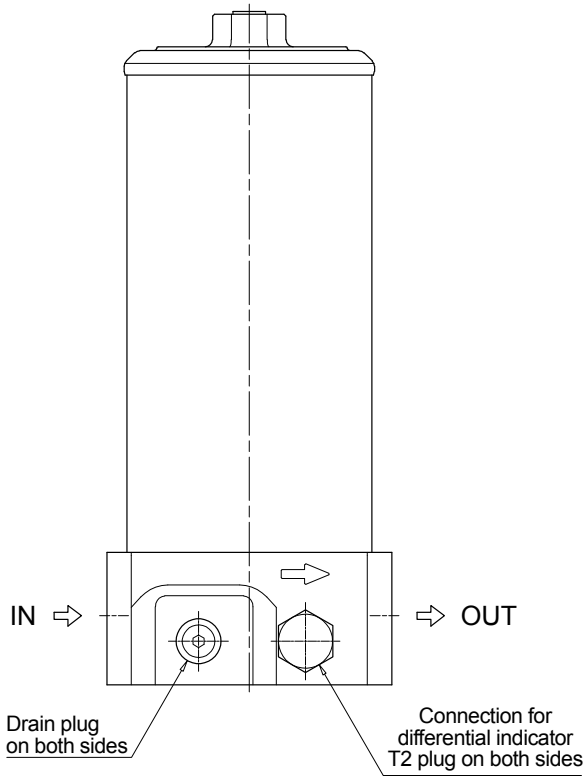
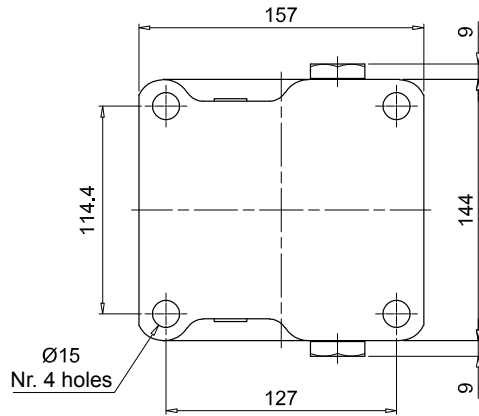

FHF325

Dimensions

FHF325

Connection G - H

Filter length	H [mm]	H2 [mm]
1	463	250
2	701	485
3	939	725

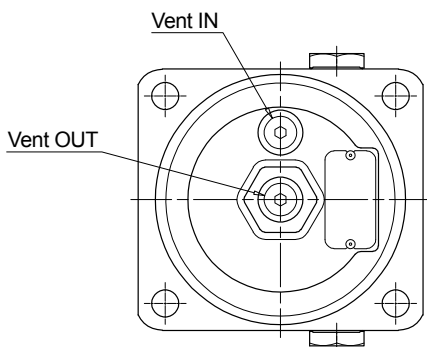
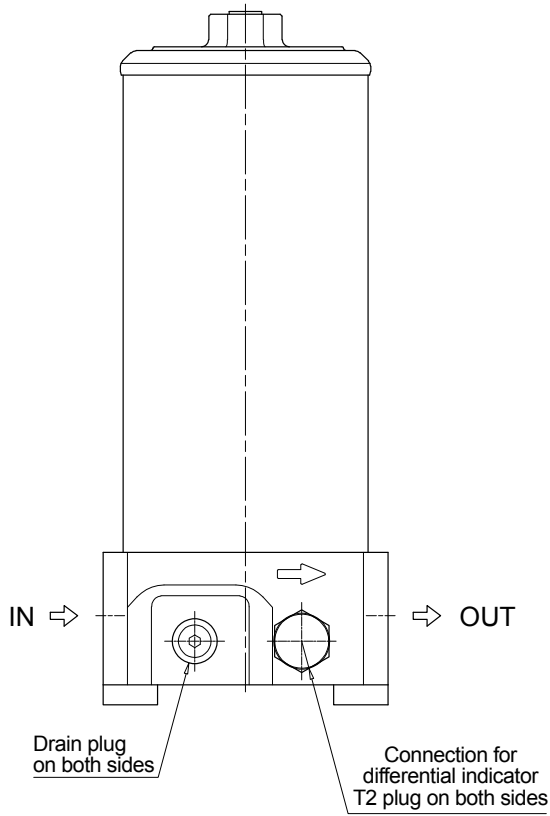
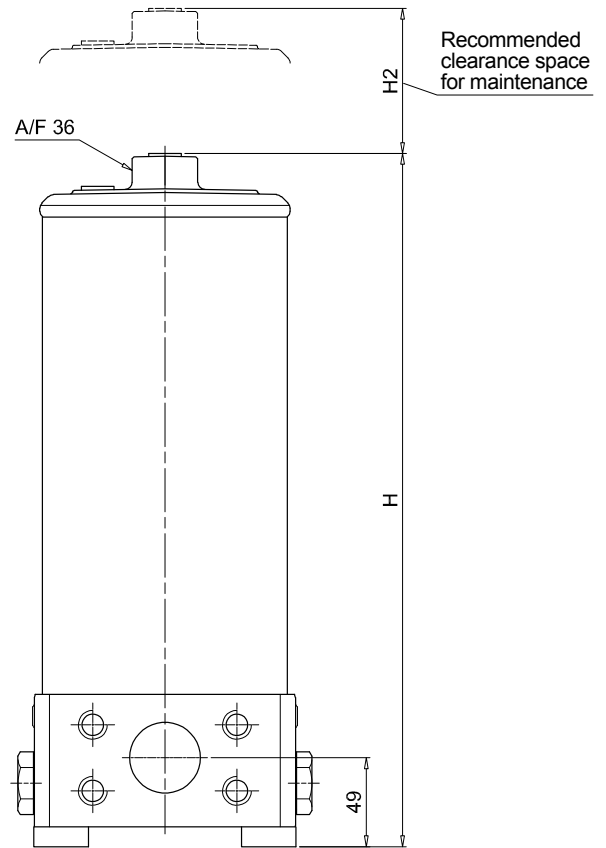
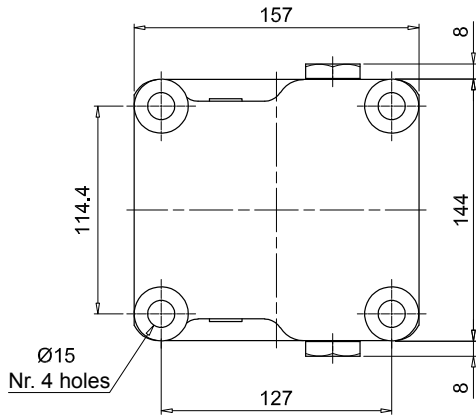

FHF325		
Connection M - N		
Filter length	H [mm]	H2 [mm]
1	452	250
2	690	485
3	928	725

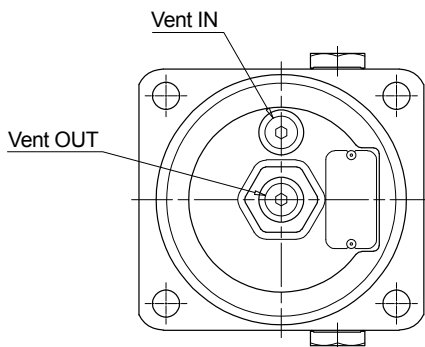
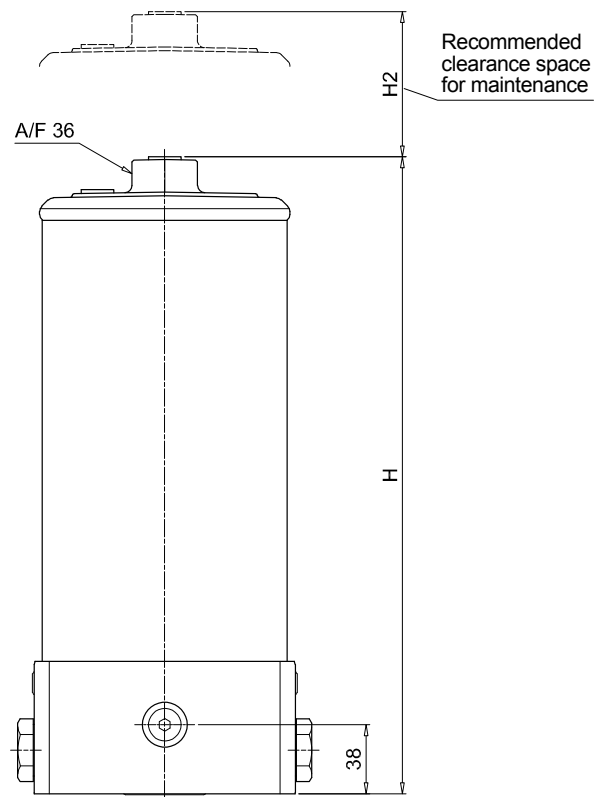
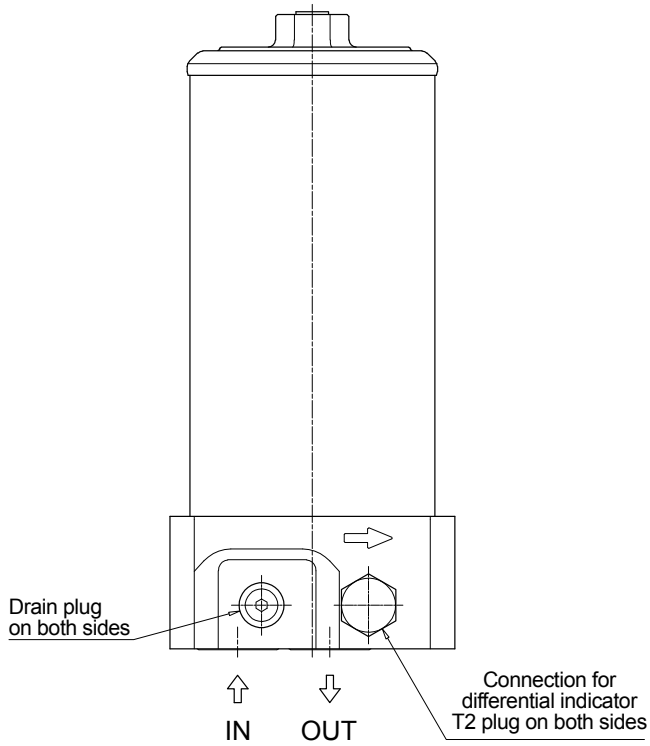
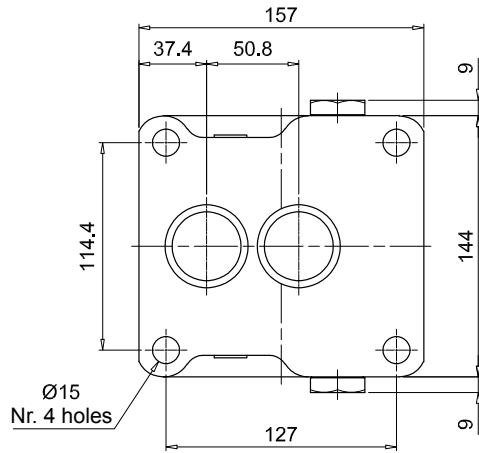

FHF325 SPARE PARTS

Filter housing according to SAE J2066 for HF4 filter elements

Order number for spare parts

FHF 325
Connections
A - B - C - G - H

Item:	Q.ty: 1 pc.	Q.ty: 1 pc.	Q.ty: 2 pc.		
Filter series	Filter element	Seal Kit code number NBR	FPM	Indicator connection plug NBR	FPM
FHF 325 A-B-C-G-H	See order table	02050588	02050589	T2H	T2V

FHF 325
Connections
M - N

Item:	Q.ty: 1 pc.	Q.ty: 1 pc.	Q.ty: 2 pc.		
Filter series	Filter element	Seal Kit code number NBR	FPM	Indicator connection plug NBR	FPM
FHF 325 M-N	See order table	02050590	02050591	T2H	T2V