

FHD series

Maximum working pressure up to 35 MPa (350 bar) - Flow rate up to 345 l/min



FILTER SIZING

INDEX

	Page
CALCULATION	23
CORRECTIVE FACTOR	24

THE CORRECT FILTER SIZING HAVE TO BE BASED ON THE TOTAL PRESSURE DROP DEPENDING BY THE APPLICATION.

FOR EXAMPLE, THE MAXIMUM TOTAL PRESSURE DROP ALLOWED BY A NEW AND CLEAN RETURN FILTER HAVE TO BE IN THE RANGE 0.4 ÷ 0.6 bar.

The pressure drop calculation is performed by adding together the value of the housing with the value of the filter element. The pressure drop Δp_c of the housing is proportional to the fluid density (kg/dm^3); all the graphs in the catalogue are referred to mineral oil with density of $0.86 \text{ kg}/\text{dm}^3$.

The filter element pressure drop Δp_e is proportional to its viscosity (mm^2/s), the corrective factor Y have to be used in case of an oil viscosity different than $30 \text{ mm}^2/\text{s}$ (cSt).

Sizing data for single filter element, head at top

Δp_c = Filter housing pressure drop [bar]

Δp_e = Filter element pressure drop [bar]

Y = Corrective factor Y (see correspondent table), depending on the filter type, on the filter element size, on the filter element length and on the filter media

Q = flow rate (l/min)

V1 reference oil viscosity = $30 \text{ mm}^2/\text{s}$ (cSt)

V2 = operating oil viscosity in mm^2/s (cSt)

Filter element pressure drop calculation with an oil viscosity different than $30 \text{ mm}^2/\text{s}$ (cSt)

$\Delta p_e = Y : 1000 \times Q \times (V2:V1)$

$\Delta p_{\text{Tot.}} = \Delta p_c + \Delta p_e$

Verification formula

$\Delta p_{\text{Tot.}} \leq \Delta p_{\text{max allowed}}$

Maximum total pressure drop (Δp_{max}) allowed by a new and clean filter

Application	Range (bar)
Suction filters	0.08 ÷ 0.10
Return filters	0.4 ÷ 0.6
	0.4 ÷ 0.6 return lines
	0.3 ÷ 0.5 lubrication lines
Low & Medium Pressure filters	0.3 ÷ 0.4 off-line in power systems
	0.1 ÷ 0.3 off-line in test benches
	0.4 ÷ 0.6 over-boost
High Pressure filters	0.8 ÷ 1.5
Stainless Steel filters	0.8 ÷ 1.5

Generic filter calculation example

Application data:

Tank top return filter

Pressure Pmax = 10 bar

Flow rate Q = 120 l/min

Viscosity V2 = $46 \text{ mm}^2/\text{s}$ (cSt)

Oil density = $0.86 \text{ kg}/\text{dm}^3$

Required filtration efficiency = $25 \mu\text{m}$ with absolute filtration

With bypass valve and G 1 1/4" inlet connection

Calculation:

$\Delta p_c = 0.03 \text{ bar}$ (see graphic below)

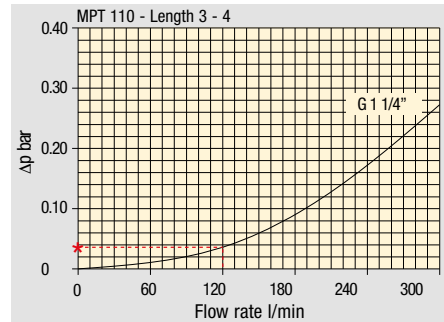

Filter housings Δp pressure drop. The curves are plotted using mineral oil with density of $0.86 \text{ kg}/\text{dm}^3$ in compliance with ISO 3968. Δp varies proportionally with density.

$\Delta p_e = (2.00 : 1000) \times 120 \times (46 : 30) = 0.37 \text{ bar}$

Filter element	Absolute filtration H Series					Nominal filtration N Series		
	A03	A06	A10	A16	A25	P10	P25	M25 M60 M90
Type								
Return filters								
MF 020	74.00	50.08	20.00	16.00	9.00	6.43	5.51	4.40
	2	29.20	24.12	8.00	7.22	5.00	3.33	2.85
	3	22.00	19.00	6.56	5.33	4.33	1.68	1.44
MF 030	74.00	50.08	20.00	16.00	9.00	6.43	5.51	3.40
MFX 030	1	28.20	24.40	8.67	8.17	6.88	4.62	3.96
	2	17.33	12.50	6.86	5.70	4.00	3.05	2.47
	3	10.25	9.00	3.65	3.33	2.50	1.63	1.32
	4	6.10	5.40	2.30	2.20	2.00	1.19	0.96
MF 100								
MFX 100								

$\Delta p_{\text{Tot.}} = 0.03 + 0.37 = 0.4 \text{ bar}$

The selection is correct because the total pressure drop value is inside the admissible range for top tank return filters.

In case the allowed max total pressure drop is not verified, it is necessary to repeat the calculation changing the filter length/size.

FILTER SIZING Corrective factor

Corrective factor Y to be used for the filter element pressure drop calculation. The values depend to the filter size and length and to the filter media.
Reference oil viscosity 30 mm²/s

Return filters

Filter element	Absolute filtration H Series					Nominal filtration N Series			
	Type	A03	A06	A10	A16	A25	P10	P25	M25 M60 M90
MF 020	1	74.00	50.08	20.00	16.00	9.00	6.43	5.51	4.40
	2	29.20	24.12	8.00	7.22	5.00	3.33	2.85	2.00
	3	22.00	19.00	6.56	5.33	4.33	1.68	1.44	1.30
MF 030 MFX 030	1	74.00	50.08	20.00	16.00	9.00	6.43	5.51	3.40
MF 100 MFX 100	1	28.20	24.40	8.67	8.17	6.88	4.62	3.96	1.25
	2	17.33	12.50	6.86	5.70	4.00	3.05	2.47	1.10
	3	10.25	9.00	3.65	3.33	2.50	1.63	1.32	0.96
	4	6.10	5.40	2.30	2.20	2.00	1.19	0.96	0.82
MF 180 MFX 180	1	3.67	3.05	1.64	1.56	1.24	1.18	1.06	0.26
	2	1.69	1.37	0.68	0.54	0.51	0.43	0.39	0.12
MF 190 MFX 190	2	1.69	1.37	0.60	0.49	0.44	0.35	0.31	0.11
MF 400 MFX 400	1	3.20	2.75	1.39	1.33	1.06	0.96	0.87	0.22
	2	2.00	1.87	0.88	0.85	0.55	0.49	0.45	0.13
	3	1.90	1.60	0.63	0.51	0.49	0.39	0.35	0.11
MF 750 MFX 750	1	1.08	0.84	0.49	0.36	0.26	0.21	0.19	0.06
MLX 250	2	3.00	3.04	1.46	1.25	1.17	-	-	M25 0.20
MLX 660	2	1.29	1.26	0.52	0.44	0.38	-	-	M25 0.10
CU 025		78.00	48.00	28.00	24.00	9.33	9.33	8.51	1.25
CU 040		25.88	20.88	10.44	10.00	3.78	3.78	3.30	1.25
CU 100		15.20	14.53	5.14	4.95	2.00	2.00	0.17	1.10
CU 250		3.25	2.55	1.55	1.35	0.71	0.71	0.59	0.25
CU 630		1.96	1.68	0.85	0.72	0.42	0.42	0.36	0.09
CU 850		1.06	0.84	0.42	0.33	0.17	0.17	0.13	0.04
MR 100	1	19.00	17.00	6.90	6.30	4.60	2.94	2.52	1.60
	2	11.70	10.80	4.40	4.30	3.00	2.94	2.52	1.37
	3	7.80	6.87	3.70	3.10	2.70	2.14	1.84	1.34
	4	5.50	4.97	2.60	2.40	2.18	1.72	1.47	1.34
	5	4.20	3.84	2.36	2.15	1.90	1.60	1.37	1.34
MR 250	1	5.35	4.85	2.32	1.92	1.50	1.38	1.20	0.15
	2	4.00	3.28	1.44	1.10	1.07	0.96	0.83	0.13
	3	2.60	2.20	1.08	1.00	0.86	0.77	0.64	0.12
	4	1.84	1.56	0.68	0.56	0.44	0.37	0.23	0.11
MR 630	1	3.10	2.48	1.32	1.14	0.92	0.83	0.73	0.09
	2	2.06	1.92	0.82	0.76	0.38	0.33	0.27	0.08
	3	1.48	1.30	0.60	0.56	0.26	0.22	0.17	0.08
	4	1.30	1.20	0.48	0.40	0.25	0.21	0.16	0.08
	5	0.74	0.65	0.30	0.28	0.13	0.10	0.08	0.04
MR 850	1	0.60	0.43	0.34	0.25	0.13	0.12	0.09	0.03
	2	0.37	0.26	0.23	0.21	0.11	0.08	0.07	0.03
	3	0.27	0.18	0.17	0.17	0.05	0.04	0.04	0.02
	4	0.23	0.16	0.13	0.12	0.04	0.03	0.03	0.02

Return / Suction filters

Filter element	Absolute filtration			
	Type	A10	A16	A25
RSX 116	1	5.12	4.33	3.85
	2	2.22	1.87	1.22
RSX 165	1	2.06	1.75	1.46
	2	1.24	1.05	0.96
	3	0.94	0.86	0.61

Filter element	Absolute filtration N Series								
	Type	A03	A06	A10	A16	A25	P10	P25	M25 M60 M90
CU 110	1	16.25	15.16	8.75	8.14	5.87	2.86	2.65	0.14
	2	12.62	10.44	6.11	6.02	4.16	1.60	1.49	0.12
	3	8.57	7.95	5.07	4.07	2.40	1.24	1.15	0.11
	4	5.76	4.05	2.80	2.36	1.14	0.91	0.85	0.05

Low & Medium pressure filters

Filter element	Absolute filtration N-W Series					Nominal filtration N Series			
	Type	A03	A06	A10	A16	A25	P10	P25	M25
CU 110	1	16.25	15.16	8.75	8.14	5.87	2.86	2.65	0.14
	2	12.62	10.44	6.11	6.02	4.15	1.60	1.49	0.12
	3	8.57	7.95	5.07	4.07	2.40	1.24	1.15	0.11
	4	5.76	4.05	2.80	2.36	1.14	0.91	0.85	0.05
CU 210	1	5.30	4.80	2.00	1.66	1.32	0.56	0.43	0.12
	2	3.44	2.95	1.24	1.09	0.70	0.42	0.35	0.09
	3	2.40	1.70	0.94	0.84	0.54	0.33	0.23	0.05
DN	016	7.95	7.20	3.00	2.49	1.98	0.84	0.65	0.18
	025	5.00	4.53	1.89	1.57	1.25	0.53	0.41	0.11
	040	3.13	2.66	1.12	0.98	0.63	0.38	0.32	0.08
CU 400	2	3.13	2.55	1.46	1.22	0.78	0.75	0.64	0.19
	3	2.15	1.70	0.94	0.78	0.50	0.40	0.34	0.10
	4	1.60	1.28	0.71	0.61	0.40	0.34	0.27	0.08
	5	1.00	0.83	0.47	0.34	0.20	0.24	0.19	0.06
	6	0.82	0.58	0.30	0.27	0.17	0.22	0.18	0.05
	CU 900	1	0.86	0.63	0.32	0.30	0.21	-	-
CU 950	2	1.03	0.80	0.59	0.40	0.26	-	-	0.05
	3	0.44	0.40	0.27	0.18	0.15	-	-	0.02
MR 630	7	0.88	0.78	0.36	0.34	0.16	0.12	0.96	0.47

Corrective factor Y to be used for the filter element pressure drop calculation. The values depend to the filter size and length and to the filter media.
Reference oil viscosity 30 mm²/s

High pressure filters

Filter element		Absolute filtration N - R Series					Nominal filtration N Series
Type		A03	A06	A10	A16	A25	M25
HP 011	1	332.71	250.07	184.32	152.36	128.36	-
	2	220.28	165.56	74.08	59.13	37.05	-
	3	123.24	92.68	41.48	33.08	20.72	-
	4	77.76	58.52	28.37	22.67	16.17	-
HP 039	2	70.66	53.20	25.77	20.57	14.67	4.90
	3	36.57	32.28	18.00	13.38	8.00	2.90
	4	26.57	23.27	12.46	8.80	5.58	2.20
HP 050	1	31.75	30.30	13.16	12.3	7.29	1.60
	2	24.25	21.26	11.70	9.09	4.90	1.40
	3	17.37	16.25	8.90	7.18	3.63	1.25
	4	12.12	10.75	6.10	5.75	3.08	1.07
	5	7.00	6.56	3.60	3.10	2.25	0.80
HP 065	1	58.50	43.46	23.16	19.66	10.71	1.28
	2	42.60	25.64	16.22	13.88	7.32	1.11
	3	20.50	15.88	8.18	6.81	3.91	0.58
HP 135	1	20.33	18.80	9.71	8.66	4.78	2.78
	2	11.14	10.16	6.60	6.38	2.22	1.11
	3	6.48	6.33	3.38	3.16	2.14	1.01
HP 150	1	17.53	15.91	7.48	6.96	5.94	1.07
	2	8.60	8.37	3.54	3.38	3.15	0.58
	3	6.53	5.90	2.93	2.79	2.12	0.49
HP 320	1	10.88	9.73	5.02	3.73	2.54	1.04
	2	4.40	3.83	1.75	1.48	0.88	0.71
	3	2.75	2.11	1.05	0.87	0.77	0.61
	4	2.12	1.77	0.98	0.78	0.55	0.47
HP 500	1	4.44	3.67	2.30	2.10	1.65	0.15
	2	3.37	2.77	1.78	1.68	1.24	0.10
	3	2.22	1.98	1.11	1.09	0.75	0.08
	4	1.81	1.33	0.93	0.86	0.68	0.05
	5	1.33	1.15	0.77	0.68	0.48	0.04

Filter element		Absolute filtration N Series					Nominal filtration N Series
Type		A03	A06	A10	A16	A25	M25
HF 320	1	3.65	2.95	2.80	1.80	0.90	0.38
	2	2.03	1.73	1.61	1.35	0.85	0.36
	3	1.84	1.42	1.32	1.22	0.80	0.35

Suction filters

Filter element	Nominal filtration N Series	
Type	P10	P25
SF 250	65	21

Stainless steel high pressure filters

Filter element		Absolute filtration N Series				
Type		A03	A06	A10	A16	A25
HP 011	1	332.71	250.07	184.32	152.36	128.36
	2	220.28	165.56	74.08	59.13	37.05
	3	123.24	92.68	41.48	33.08	20.72
	4	77.76	58.52	28.37	22.67	16.17
HP 039	2	70.66	53.20	25.77	20.57	14.67
	3	36.57	32.28	18.00	13.38	8.00
	4	26.57	23.27	12.46	8.80	5.58
HP 050	1	31.75	30.30	13.16	12.3	7.29
	2	24.25	21.26	11.70	9.09	4.90
	3	17.37	16.25	8.90	7.18	3.63
	4	12.12	10.75	6.10	5.75	3.08
	5	7.00	6.56	3.60	3.10	2.25
HP 135	1	20.33	18.80	9.71	8.66	4.78
	2	11.14	10.16	6.60	6.38	2.22
	3	6.48	6.33	3.38	3.16	2.14

Filter element		Absolute filtration H - U Series				
Type		A03	A06	A10	A16	A25
HP 011	1	424.58	319.74	235.17	194.44	163.78
	2	281.06	211.25	94.53	75.45	47.26
	3	130.14	97.50	43.63	34.82	21.81
	4	109.39	82.25	36.79	29.37	18.40
HP 039	2	70.66	53.20	25.77	20.57	14.67
	3	36.57	32.28	18.00	13.38	8.00
	4	26.57	23.27	12.46	8.80	5.58
HP 050	1	47.33	34.25	21.50	20.50	14.71
	2	29.10	25.95	14.04	10.90	5.88
	3	20.85	19.50	10.68	8.61	4.36
	4	14.55	12.90	7.32	6.90	3.69
	5	9.86	9.34	6.40	4.80	2.50
HP 135	1	29.16	25.33	13.00	12.47	5.92
	2	14.28	11.04	7.86	7.60	4.44
	3	8.96	7.46	4.89	4.16	3.07

FILTER SIZING Selection Software

Step 1 Select "FILTERS"



Step 2 Choose filter group (Return Filter, Pressure Filter, etc.)



Step 3 Choose filter type (MPF, MPT, etc.) in function of the max working pressure and the max flow rate



Step 4 Push "PROCEED"

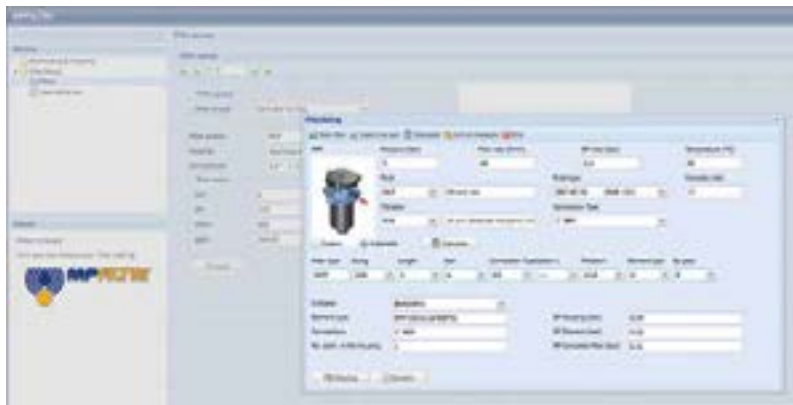

Step 5

Insert all application data to calculate the filter size following the sequence:

- working pressure
- working flow rate
- working pressure drop
- working temperature
- fluid material and fluid type
- filtration media
- connection type

Step 6

Push "CALCULATE" to have result; in case of any mistake, the system will advice which parameter is out of range to allow to modify/adjust the selection



Step 7

Download PDF Datasheet "Report.aspx" pushing the button "Drawing"

FHD series

Maximum working pressure up to 35 MPa (350 bar) - Flow rate up to 345 l/min



High Pressure filters

Duplex

Maximum working pressure up to 35 MPa (350 bar)

Flow rate up to 345 l/min

FHD is a range of high pressure duplex filter with integrated changeover function to allow the filter element replacement without the system shut-down.

They are directly connected to the lines of the system through the hydraulic fittings.

Available features:

- Female threaded connections up to 1 1/4" and flanged connections up to 1 1/2", for a maximum flow rate of 345 l/min
- Fine filtration rating, to get a good cleanliness level into the system
- Balancing valve integrated in the changeover lever, to equalize the housing pressure before the switch
- Bypass valve, to relieve excessive pressure drop across the filter media
- Vent ports, to avoid air trapped into the filter going into the system
- Drain ports, to remove the fluid from the housing prior the maintenance work
- Low collapse filter element "N", for use with filters provided with bypass valve
- High collapse filter element "H", for use with filters not provided with bypass valve
- Low collapse filter element with external support "R", for filter element protection against the back pressure caused by the check valve or the reverse flow in filters provided with the bypass valve
- High collapse filter element with external support "S", for filter element protection against the back pressure caused by the check valve or the reverse flow in filters not provided with the bypass valve
- Visual, electrical and electronic differential clogging indicators

Common applications:

- System where shut-down causes high costs
- System where shut-down causes safety issues

Filter housing materials

- Head: Phosphatized cast iron
- Housing: Phosphatized steel
- Bypass valve: Steel

Pressure

- Test pressure: 52.5 MPa (525 bar)
- Burst pressure: 105 MPa (1050 bar)
- Pulse pressure fatigue test: 1 000 000 cycles with pressure from 0 to 35 MPa (350 bar)

Bypass valve

- Opening pressure 600 kPa (6 bar) ±10%
- Other opening pressures on request.

Δp element type

- Microfibre filter elements - series N: 20 bar
- Microfibre filter elements - series R: 20 bar (not available for FHD 021)
- Microfibre filter elements - series H: 210 bar (only for FHD 021)
- Microfibre filter elements - series S: 210 bar (not available for FHD 021)
- Wire mesh filter elements - series N: 20 bar
- Fluid flow through the filter element from OUT to IN.

Seals

- Standard NBR series A
- Optional FPM series V

Temperature

From -25 °C to +110 °C

Connections

In-line Inlet/Outlet 90°

Note

FHD filters are provided for vertical mounting



Weights [kg] and volumes [dm³]

Filter series	Weights [kg]						Volumes [dm ³]					
	Length	1	2	3	4	5	Length	1	2	3	4	5
FHD 021	-	8.0	9.0	9.9	-	-	-	0.06	0.12	0.22	-	-
FHD 051	-	16.9	17.5	18.5	19.8	-	-	0.31	0.41	0.53	0.83	-
FHD 326	43.0	50.0	54.0	-	-	-	0.88	1.60	2.37	-	-	-
FHD 333	-	74.0	79.0	98.0	-	-	-	1.75	2.52	3.35	-	-

Filter housings Δp pressure drop

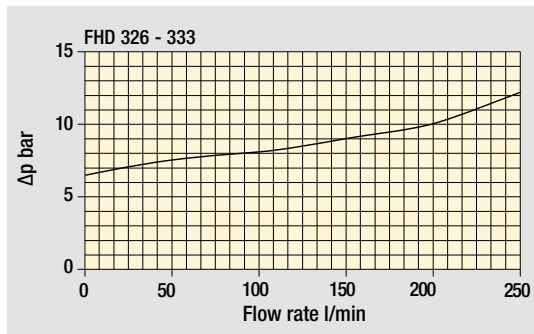
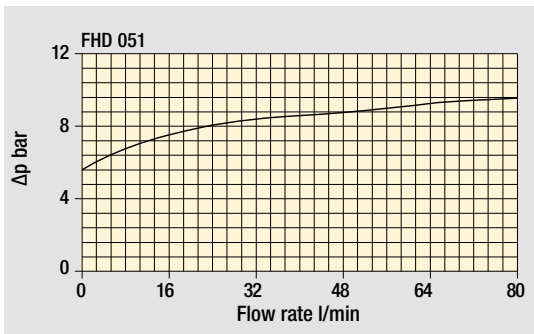
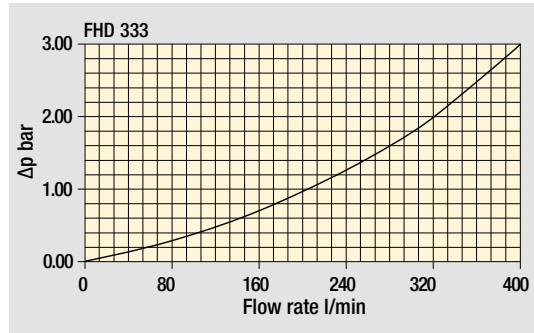
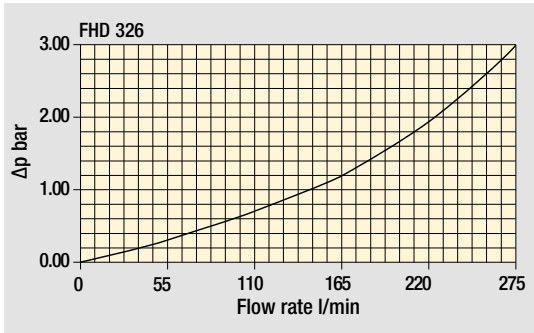
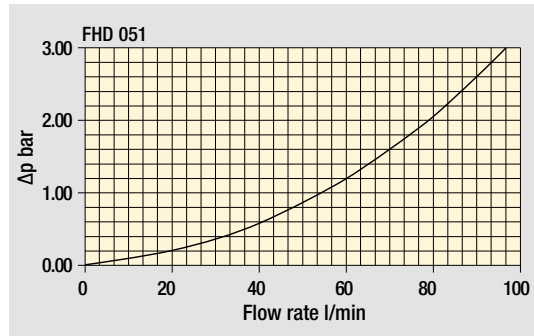
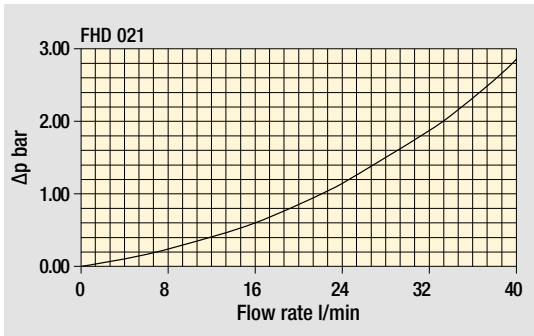

Bypass valve pressure drop

The curves are plotted using mineral oil with density of 0.86 kg/dm^3 in compliance with ISO 3968.
 Δp varies proportionally with density.

FHD GENERAL INFORMATION

Flow rates [l/min]

Size	Length	Filter element design - H Series					
		A03	A06	A10	A16	A25	M25
FHD 021	2	6	8	14	16	19	26
	3	10	12	18	20	22	27
	4	13	16	21	22	24	27

Size	Length	Filter element design - R Series						N Series	Filter element design - S Series				
		A03	A06	A10	A16	A25	M25		A03	A06	A10	A16	A25
FHD 051	2	39	41	51	54	59	64	35	37	48	51	58	
	3	45	46	54	56	61	65	41	43	52	54	60	
	4	50	52	58	58	62	65	47	49	56	56	61	
	5	56	57	61	62	63	65	53	53	57	59	63	
FHD 326	1	93	99	131	142	154	171	83	87	117	120	146	
	2	136	141	163	166	173	176	119	128	149	151	163	
	3	152	159	171	174	175	177	139	148	161	163	170	
FHD 333	2	175	184	224	230	245	249	147	162	199	201	225	
	3	204	217	241	245	247	252	179	196	221	224	238	
	4	216	224	242	247	253	255	196	204	223	225	239	

Maximum flow rate for a complete pressure filter with a pressure drop $\Delta p = 1.5$ bar.

The reference fluid has a kinematic viscosity of 30 mm²/s (cSt) and a density of 0.86 kg/dm³.

For different pressure drop or fluid viscosity we recommend to use our selection software available on www.mpfiltri.com.

Please, contact our Sales Department for further additional information.

Hydraulic symbols

Filter series	Style S	Style B	Style B
FHD 021	•		
FHD 051	•	•	
FHD 326	•		•
FHD 333	•		•

--	--	--

Designation & Ordering code

COMPLETE FILTER

Series and size FHD021	Configuration example: FHD021 4 S A G1 A06 H P01									
Length 2 3 4										
Valves S Without bypass										
Seals A NBR V FPM										
Connections G1 G 1/2" G2 1/2" NPT G3 SAE 8 - 3/4" - 16 UNF										
Filtration rating (filter media)										
A03 Inorganic microfiber 3 µm	A16 Inorganic microfiber 16 µm									
A06 Inorganic microfiber 6 µm	A25 Inorganic microfiber 25 µm									
A10 Inorganic microfiber 10 µm	M25 Wire mesh 25 µm									

Element Δp	Filtration rating		Execution
	Axx	M25	
N 20 bar		•	P01 MP Filtri standard
H 210 bar	•		Pxx Customized

FILTER ELEMENT

Element series and size HP011	Configuration example: HP011 4 A06 A H P01					
Element length 2 3 4						
Filtration rating (filter media)						
A03 Inorganic microfiber 3 µm	A16 Inorganic microfiber 16 µm					
A06 Inorganic microfiber 6 µm	A25 Inorganic microfiber 25 µm					
A10 Inorganic microfiber 10 µm	M25 Wire mesh 25 µm					

Seals	Element Δp	Filtration rating		Execution
		Axx	M25	
A NBR	N 20 bar		•	P01 MP Filtri standard
V FPM	H 210 bar	•	•	Pxx Customized

ACCESSORIES

Differential indicators	page		page
DEA Electrical differential indicator	563	DLE Electrical / visual differential indicator	566
DEH Hazardous area electronic differential indicator	563-564	DTA Electronic differential indicator	567
DEM Electrical differential indicator	564-565	DVA Visual differential indicator	567
DLA Electrical / visual differential indicator	565-566	DVM Visual differential indicator	567
Additional features	page		
T2 Plug	568		

FHDO21	
Filter length	H [mm]
2	172
3	222
4	272
Connections	R
G1	M6
G2 - G3	1/4" UNC

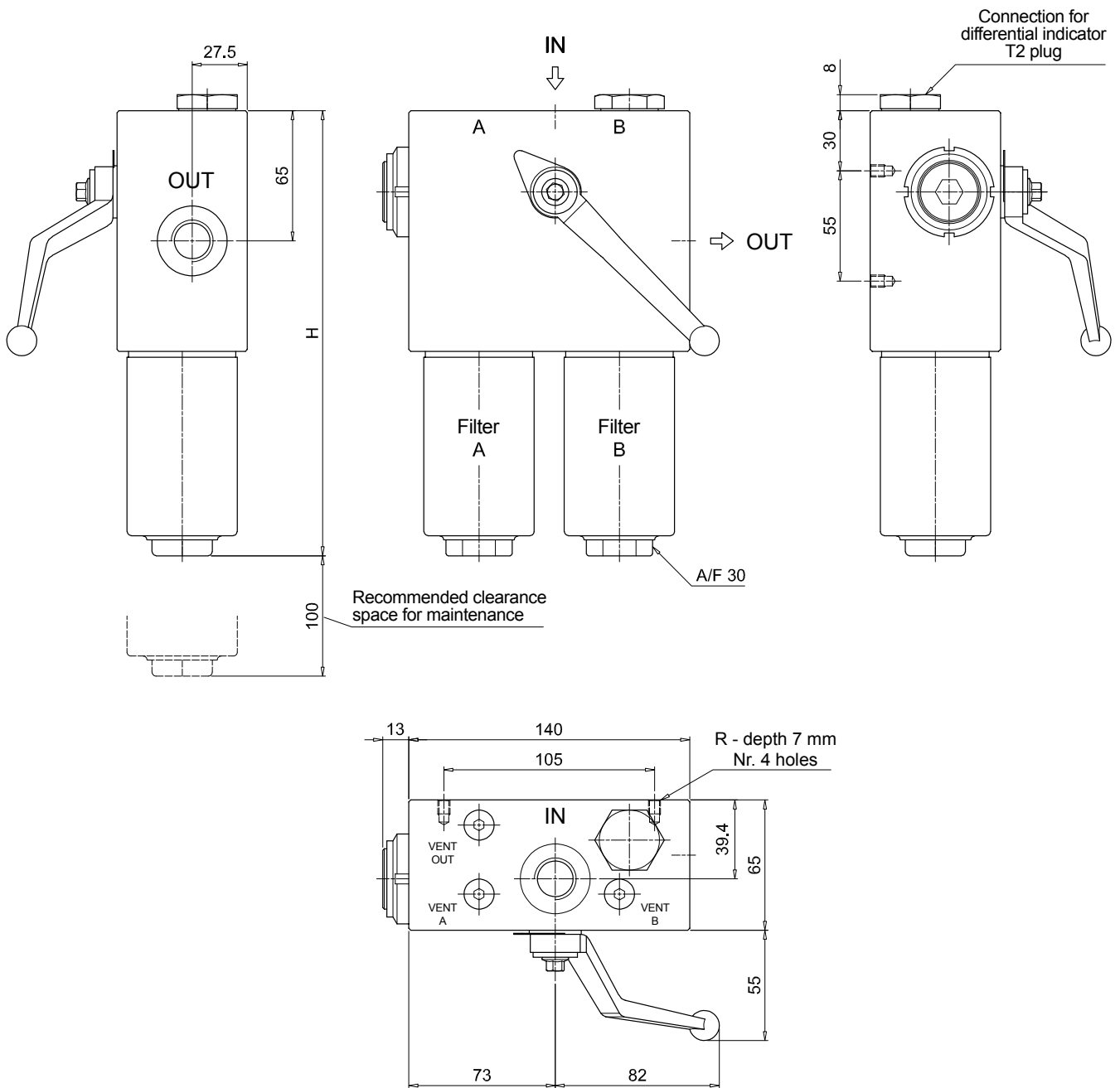

FHD FHD051 - FHD326 - FHD333

Designation & Ordering code

COMPLETE FILTER

Series and size Configuration example: **FHD326** | **3** | **S** | **A** | **G1** | **M25** | **N** | **P01**

FHD051 | FHD326 | FHD333

Length	FHD051	FHD326	FHD333
1		•	
2	•	•	•
3	•	•	•
4	•		•
5	•		

Valves

S	Without bypass
B	With bypass 6 bar

Seals

A	NBR
V	FPM

Connections	FHD051	FHD326	FHD333
G1	G 3/4"	G 1 1/4"	-
G2	3/4" NPT	1 1/4" NPT	-
G3	G 1/2"	SAE 20 - 1 5/8" - 12 UN	-
G4	1/2" NPT	-	-
G5	SAE 8 - 3/4" - 16 UNF	-	-
G6	SAE 12 - 1 1/16" - 12 UN	-	-
F1	-	-	1 1/2" 6000 psi/M
F2	-	-	1 1/2" 6000 psi/UNC

Filtration rating (filter media)

A03	Inorganic microfiber	3 µm
A06	Inorganic microfiber	6 µm
A10	Inorganic microfiber	10 µm
A16	Inorganic microfiber	16 µm
A25	Inorganic microfiber	25 µm
M25	Wire mesh	25 µm

Element Δp	Filtration rating		Execution
	Axx	M25	
N 20 bar		•	P01 MP Filtri standard
R 20 bar	•	•	Pxx Customized
S 210 bar	•	•	

FILTER ELEMENT

Element series and size Configuration example: **HP320** | **3** | **M25** | **A** | **N** | **P01**

FHD051 | FHD326 | FHD333

HP050	•		
HP320		•	•

Element length	HP050	HP320
1		•
2	•	•
3	•	•
4	•	•
5	•	

Filtration rating (filter media)

A03	Inorganic microfiber	3 µm
A06	Inorganic microfiber	6 µm
A10	Inorganic microfiber	10 µm
A16	Inorganic microfiber	16 µm
A25	Inorganic microfiber	25 µm
M25	Wire mesh	25 µm

Seals	Filtration rating		Execution
	Axx	M25	
A NBR		•	P01 MP Filtri standard
V FPM	•	•	Pxx Customized
	•	•	

ACCESSORIES

Differential indicators	page		page
DEA Electrical differential indicator	563	DLE Electrical / visual differential indicator	566
DEH Hazardous area electronic differential indicator	563-564	DTA Electronic differential indicator	567
DEM Electrical differential indicator	564-565	DVA Visual differential indicator	567
DLA Electrical / visual differential indicator	565-566	DVM Visual differential indicator	567

Additional features	page
T2 Plug	568

FHD051			
Filter length	H [mm]		
2	253		
3	295		
4	343		
5	465		
Connections	R		
G1	M6		
G2	1/4" UNC		
G3	M6		
G4-G5-G6	1/4" UNC		
Valves	L [mm]	L1 [mm]	M [mm]
S	168	138	84
B	182.5	152.5	98.5

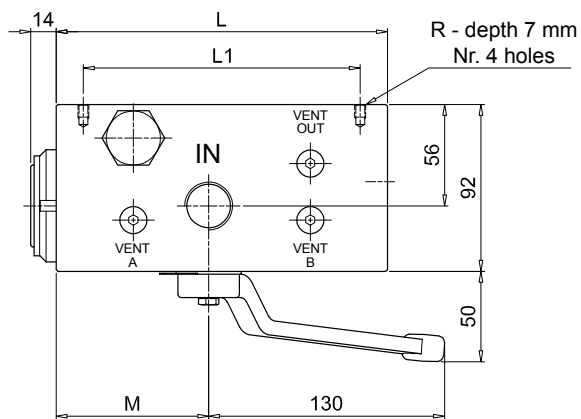
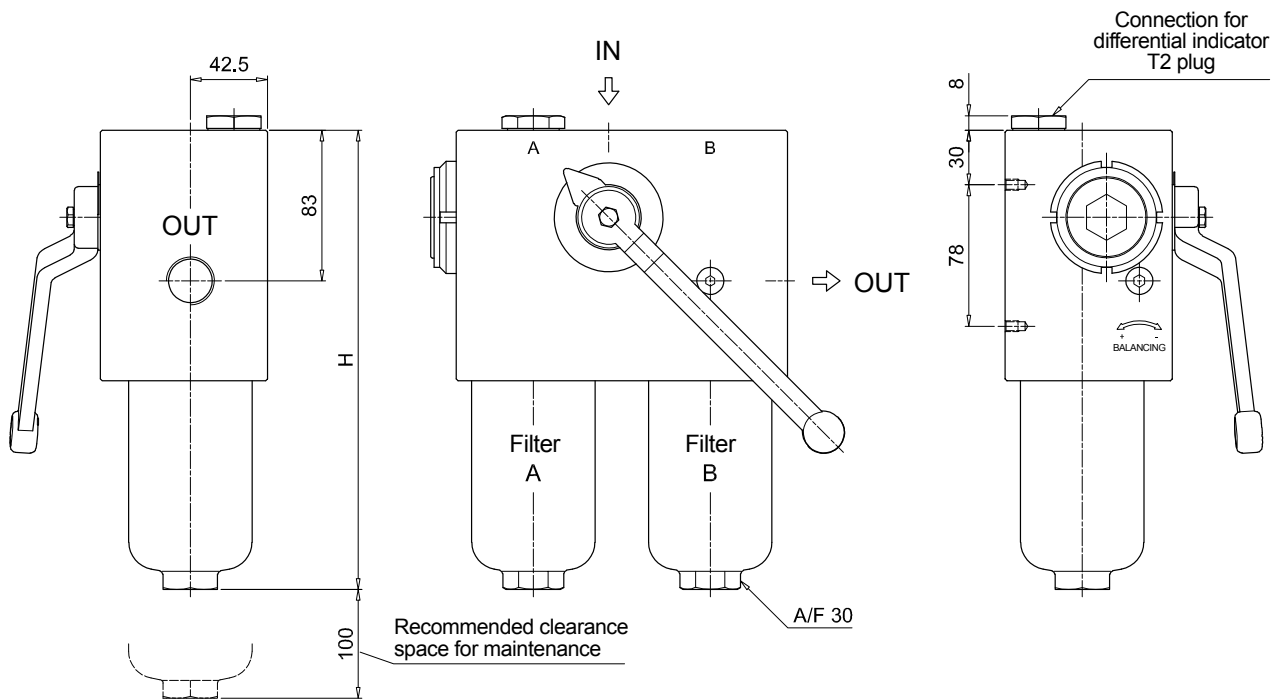

FHD FHD051 - FHD326 - FHD333

Dimensions

FHD326

Filter length	H [mm]
1	309
2	432
3	564

Connections	R
G1	M10
G2 - G3	3/8" UNC

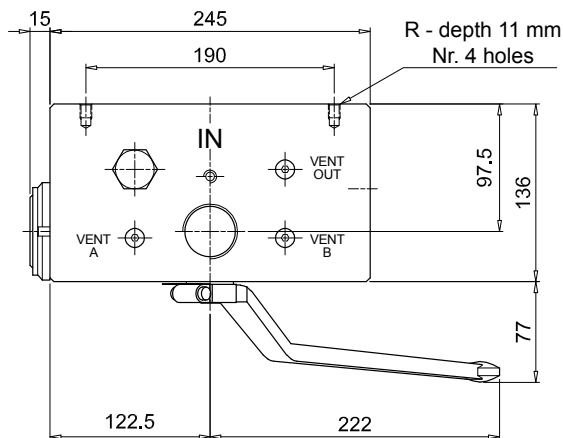
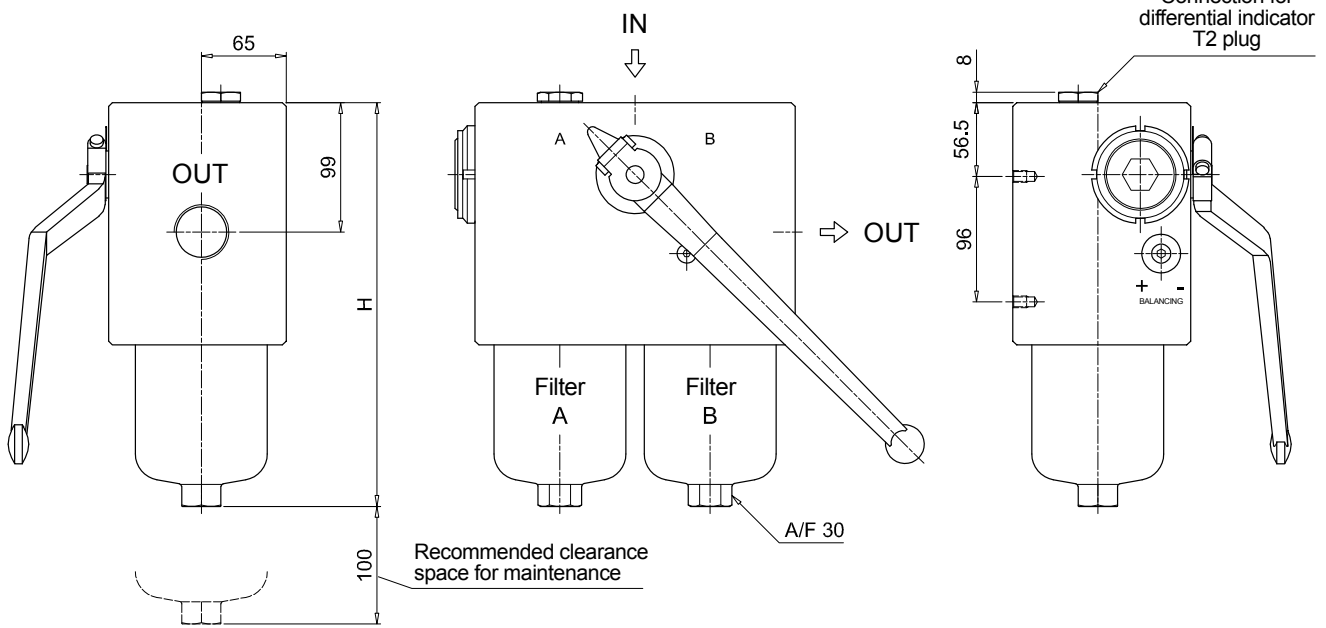

FHD333	
Length 2 - 3	
Filter length	H [mm]
2	479
3	612
Connections	R
F1	M10
F2	3/8" UNC

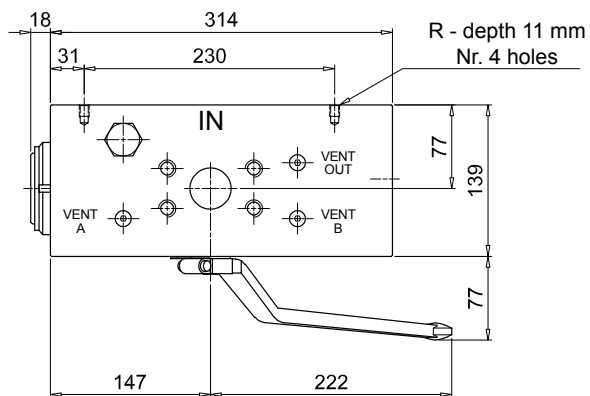
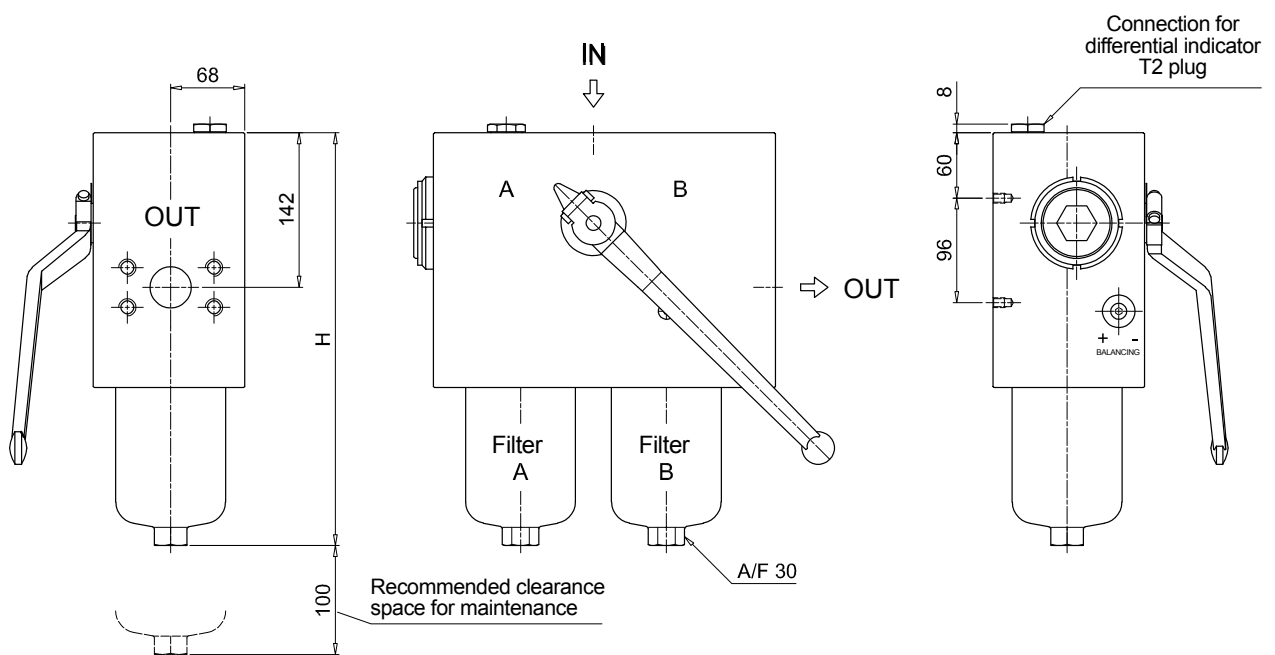

FHD FHD051 - FHD326 - FHD333

Dimensions

FHD333	
Length 4	
Connections	R
F1	M10
F2	3/8" UNC

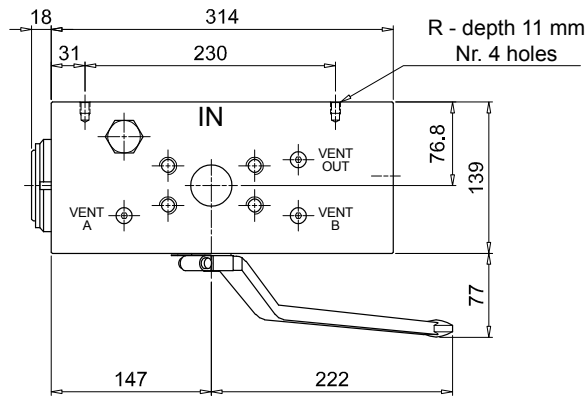
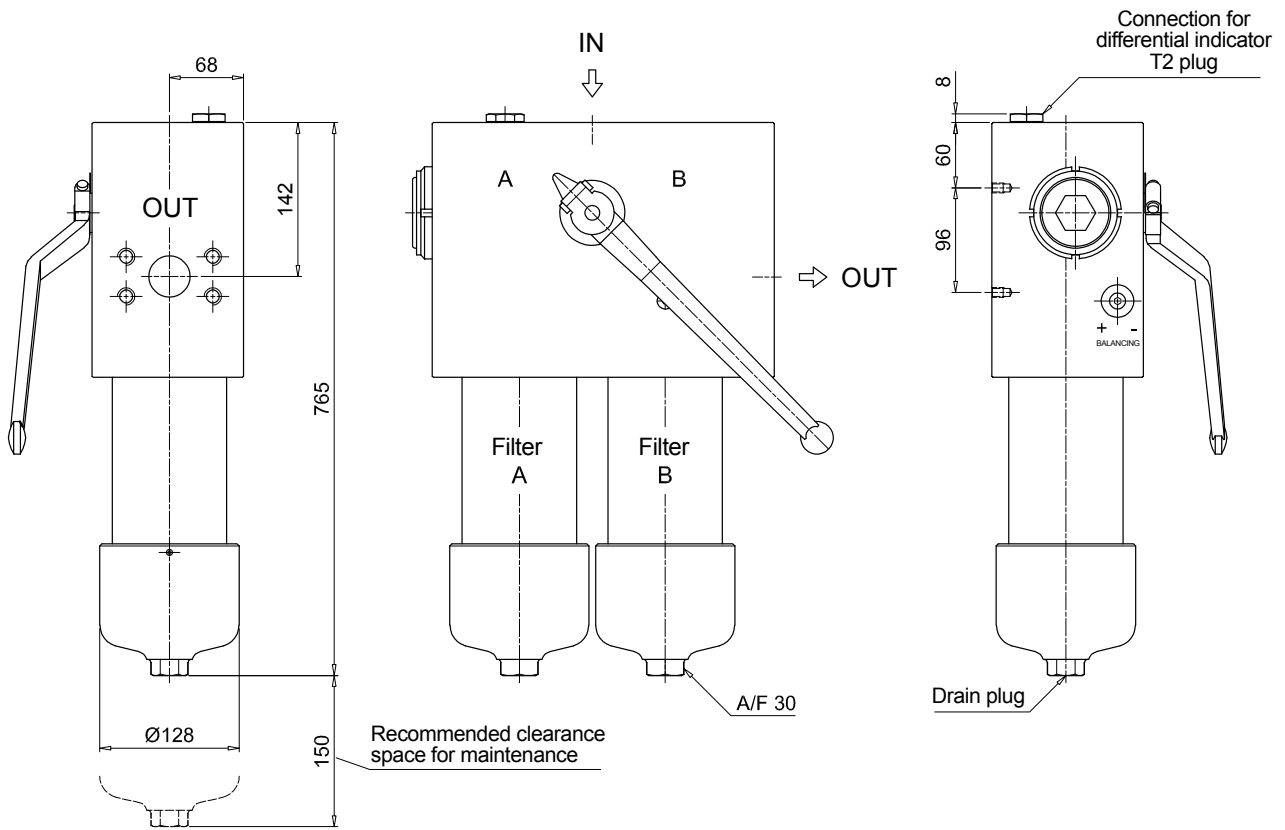

FHD 021 - 051 - 326 - 333

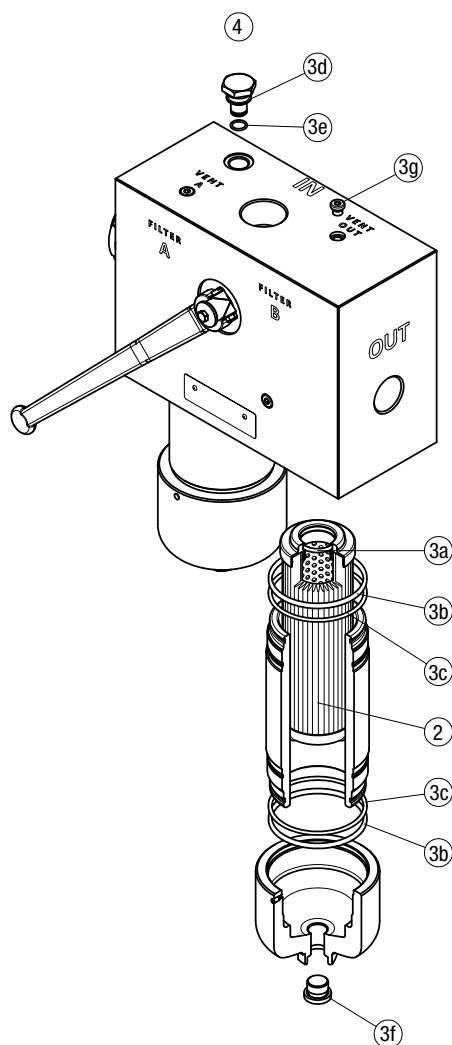

Item:	Q.ty: 1 pc.	Q.ty: 1 pc.		Q.ty: 1 pc.	
Filter series	Filter element	Seal Kit code number		Indicator connection plug	
FHD 021	See order table	NBR	FPM	NBR	FPM
FHD 051	See order table	02050511	02050512	T2H	T2V
FHD 326-333	See order table	02050420	02050421		
		02050377	02050378		